

The Brinell hardness test. Mark of precision in quality control.

Permanent proof of hardness test . . .

The Brinell tester leaves behind a telltale indentation that's harmless to the tested component. Yet it's lasting proof that a test was made. The benefits of a Brinell test are:

- Material to be tested doesn't have to be polished
- Indentation can be checked and rechecked anytime
- Test procedure requires a minimum of time

New metals and hardness testing . . .

Today hardness tests are needed more than ever with the advent of new alloys and new stress conditions. They're especially important when metals are heat treated. The Brinell test is universally recognized as an excellent means of comparing the hardness of various metals. Even tests made by different operators are more consistent than other forms of testing.

The King Brinell tester. Nothing beats it for accuracy, versatility and durability.

Can be used as both a bench and a portable tester.

. . . so you'll never have to buy separate testers again.

Accuracy guaranteed to within 1/2 of 1%.

. . . exceeds minimum ASTM standards; meets U.S. National Bureau of Standards requirements and British Standard #240, Pt. 2, 1964, Sect. 1.

Requires only one operator. Minimum set-up and handling time.

. . . so you save on labor costs.

Light, easy to maneuver.

Versatile enough to test any size, any shape, anywhere.

Built to last.

. . . some have been working over 35 years without factory service.

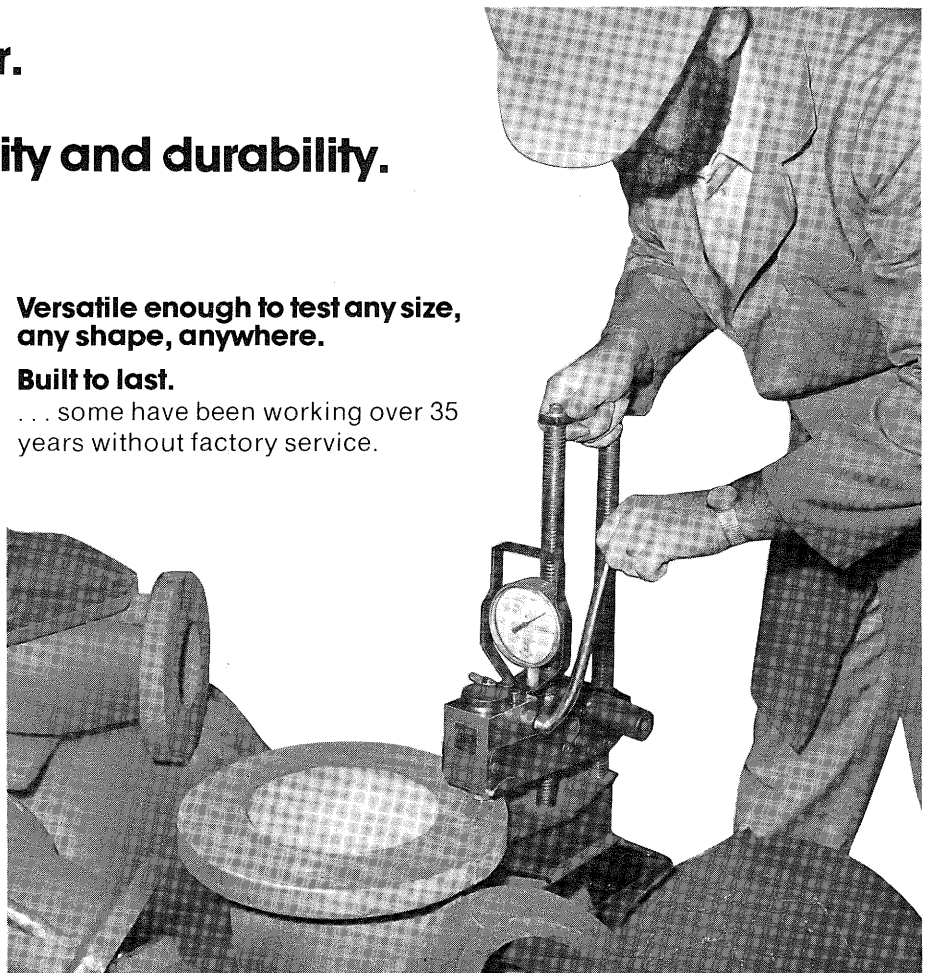

The King Brinell hardness tester.

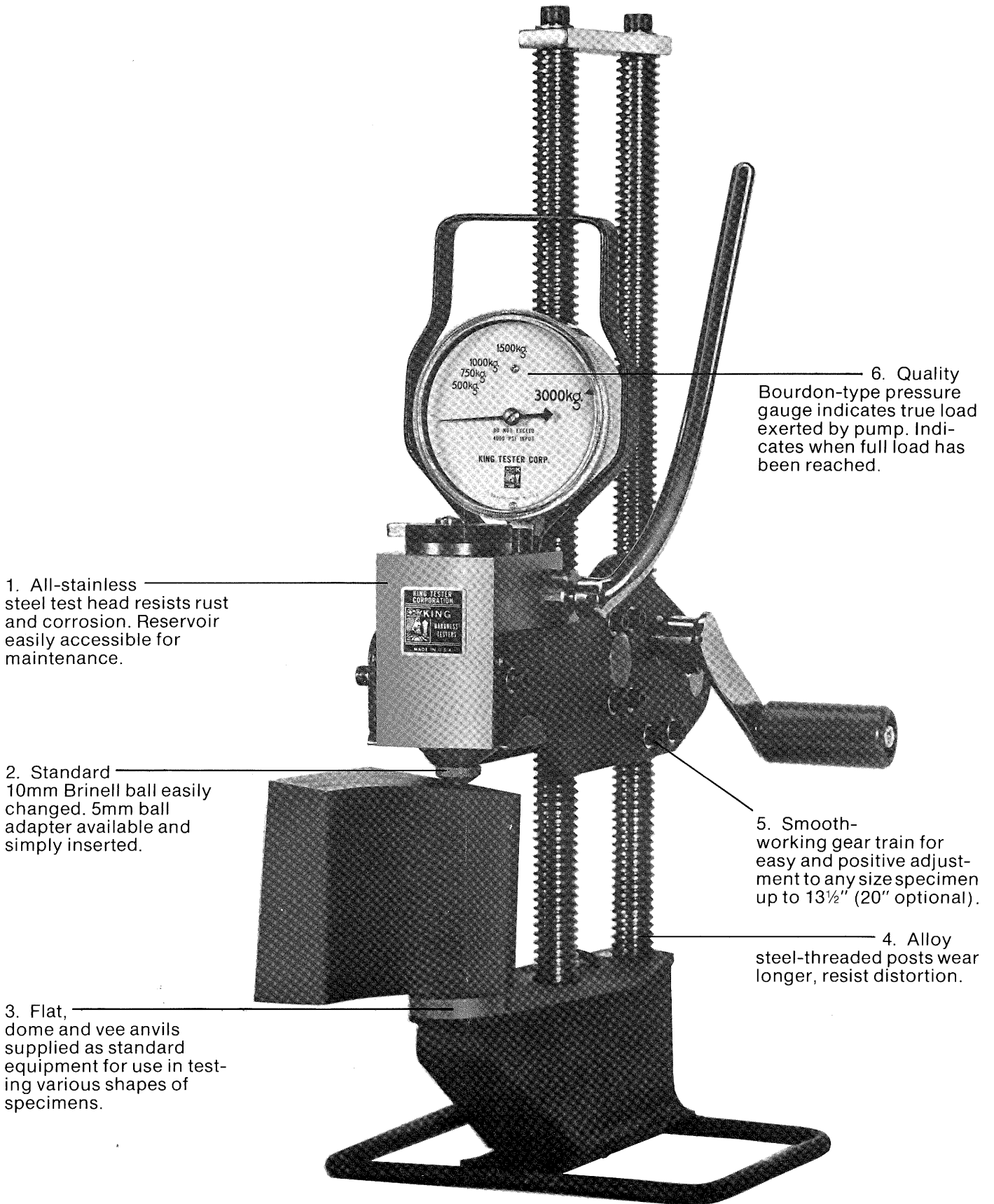

1. All-stainless steel test head resists rust and corrosion. Reservoir easily accessible for maintenance.

2. Standard 10mm Brinell ball easily changed. 5mm ball adapter available and simply inserted.

3. Flat, dome and vee anvils supplied as standard equipment for use in testing various shapes of specimens.

6. Quality Bourdon-type pressure gauge indicates true load exerted by pump. Indicates when full load has been reached.

5. Smooth-working gear train for easy and positive adjustment to any size specimen up to 13½" (20" optional).

4. Alloy steel-threaded posts wear longer, resist distortion.

